

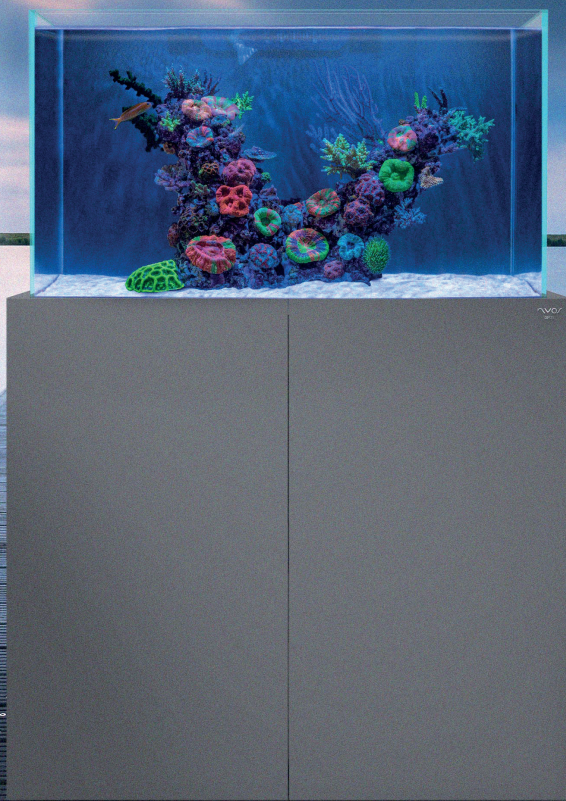

EN

HIGH LEVEL REEFING

OPUS® G2



USER GUIDE
Pro-Line® / Slim-Line®

VIDEO INSTRUCTIONS
STARTING THE TANK



VIDEO INSTRUCTIONS
EQUIPMENT INSTALLATION

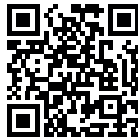

VIDEO INSTRUCTIONS
INTRODUCING LIVE STOCK



CONGRATULATIONS

Congratulations on your new Nyos® OPUS® G2 aquarium.

Before putting the product into operation, please read the user guide and safety instructions carefully.

CONTENTS

SAFETY INSTRUCTIONS	4
BEFORE ASSEMBLY	6
FUNCTIONALITY AND EQUIPMENT REQUIRED	8
STARTING THE TANK	11
MAINTENANCE AND CARE	14

SAFETY INSTRUCTIONS

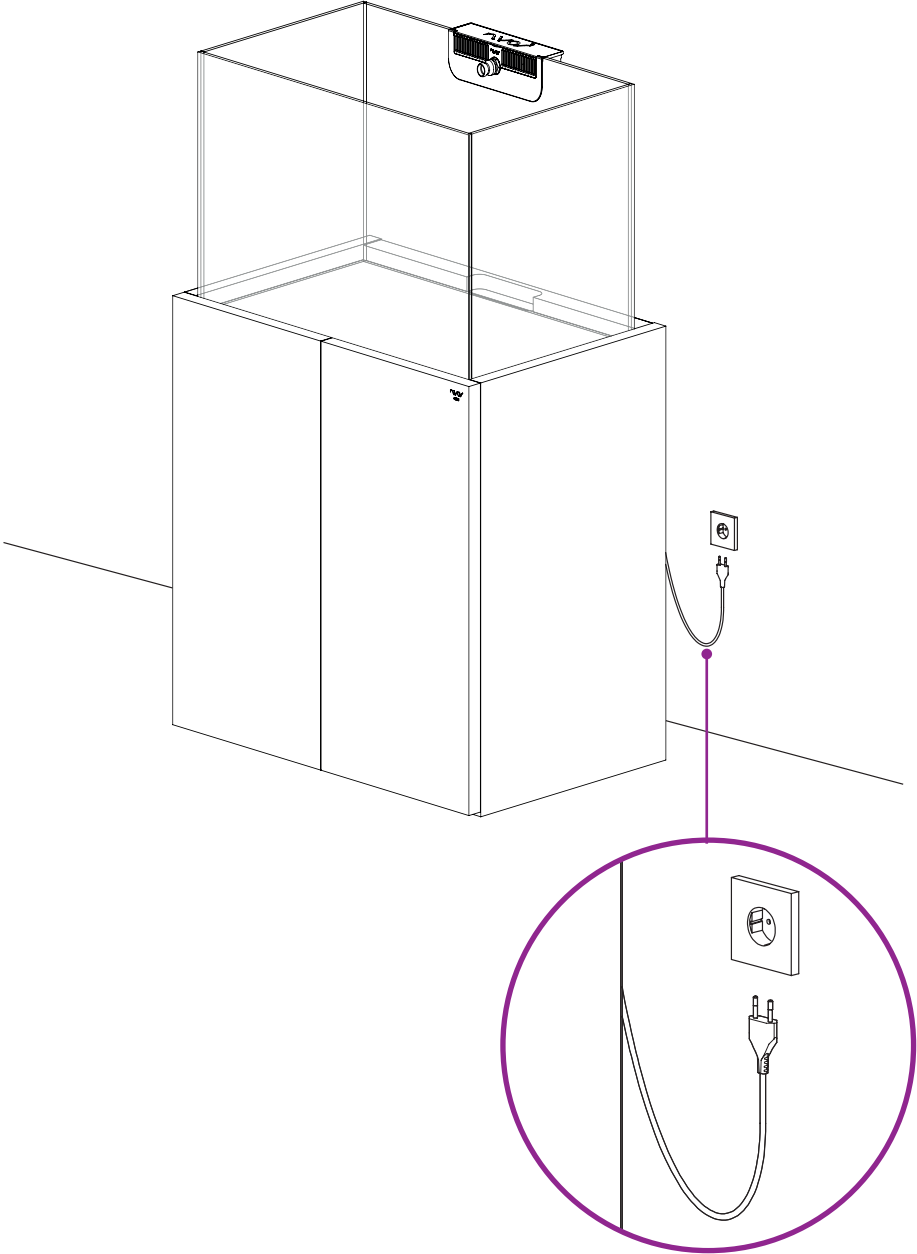

(Fig. 1)

SAFETY INSTRUCTIONS

- Read the user guide carefully and fully prior to putting the aquarium into operation.
- When using electrical equipment in or in close proximity to the aquarium, observe the instructions of the respective manufacturer.
- With all electrical equipment, the cable must form a drip loop so that no water is able to flow along the cable in the direction of the socket. The drip loop must be positioned above the respective water level (Fig. 1).
- This product is approved exclusively for use indoors and only for aquarium applications.
- Do not move the aquarium when filled, or attempt to lift it.
- Even when the aquarium is empty, never lift it by the overflow box.
- Before putting hands in the water, disconnect all electrical equipment from the power supply.
- This product is not intended for use by persons (including children) with limited physical, sensory or mental capabilities, unless they are supervised by a person responsible for their safety, or have received instruction from such a person on how to use the product. Children must be supervised to ensure they do not play with the product.

BEFORE ASSEMBLY

SELECTION OF THE INSTALLATION SITE

- The floor on which the OPUS® G2 is installed must be level.
- The floor on which the OPUS® G2 is installed must be sufficiently load-bearing. The OPUS® G2 has a base surface of approx. 90x60cm (39 x 26 in) and a weight of approx. 500 kgs (1,100 lbs) when filled. In case of doubt, consult a structural engineer in this regard.
- The aquarium should not be exposed to direct sunlight because this can result in undesirable algae forming.
- The room should exhibit a normal room temperature of approx. 20 – 24 °C (68 – 75 ° F).
- Do not install next to a radiator or an air conditioning system.

BEFORE ASSEMBLY

- Ensure sufficient and regular ventilation of the room.
- In order to guarantee sufficient space for cables and ventilation of the cabinet, the rear side of the OPUS® G2 should exhibit a distance of approx. 8cm (3 in) from the wall.
- For reasons of accessibility, the OPUS® G2 should exhibit a distance of approx. 60cm (24 in) from neighbouring walls or furniture on both the right and left side (Fig. 2).
- Make sure the floor cover around the aquarium is appropriately waterproof.
- Do not place any objects that could corrode due to salt water, or that could be damaged by water, close to the aquarium.

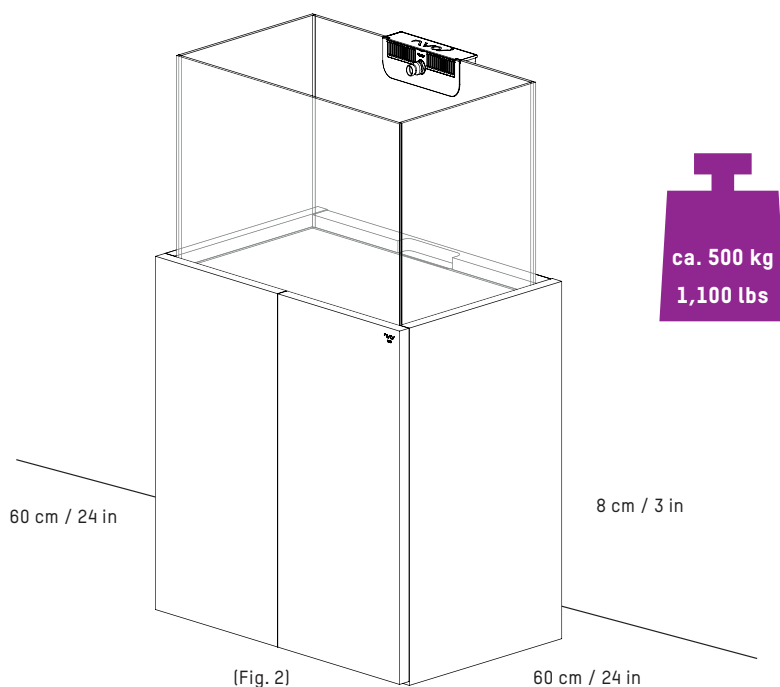

FUNCTIONALITY AND EQUIPMENT REQUIRED

FUNCTIONALITY OF PIPEWORK AND VALVE:

- The water from the display tank runs via the overflow box into the main outflow and then into chamber 1 of the sump (Fig. 3).
- The second outflow in the overflow box is an emergency outflow and is only used if the main outflow is blocked.
- The adjusting valve on the main outflow controls the water flow to the sump and ensures that the outflow noise is kept to a minimum.

FUNCTIONALITY AND STRUCTURE OF SUMP:

Chamber 1: Sedimentation chamber for the outflow water from the display tank.

Chamber 2: Filter sock filters dirt particles out of the water.

Chamber 3: The **main filter chamber**, also known as the skimmer chamber, has a constant water level. It is possible to install further filters here, such as a media reactor (Nyos® TORQ®) for example.

Chamber 4: Bubble trap, in which a coarse filter sponge can be placed if necessary.

Chamber 5: Return Chamber. In this chamber, the water is fed back into the display tank via the return pump. As the water level in the return chamber varies, this is where the evaporated water needs to be replenished via the auto top off system.

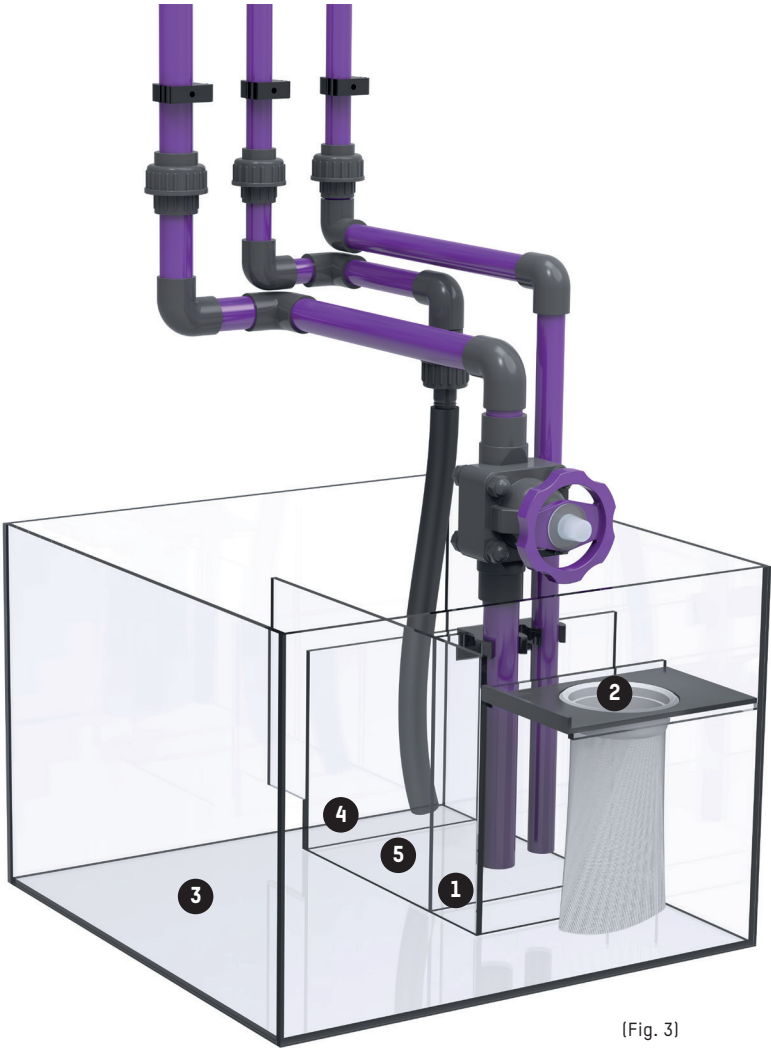

(Fig. 3)

FUNCTIONALITY AND EQUIPMENT REQUIRED

OVERVIEW OF TECHNICAL EQUIPMENT REQUIRED

We recommend the following components:

Component	Recommendation für OPUS® 300	Place of Installation
Skimmer	Nyos® QUANTUM® 120	Main filter chamber
Return Pump	Nyos® Viper 2.0 or	Return chamber
	EcoTech Marine Vectra S	
Light	2 x Ecotech Marine Radion XR 15W	Display tank
Flow	2 x Ecotech Marine Vortech MP10wQD or 2x Aqua Illumination Nero 5	Display tank
Media reactor	Nyos® TORQ®	Main filter chamber
Auto top off	Tunze Osmolator	Return chamber
Heater	100W	Main filter chamber

INFORMATION ON THE RETURN PUMP:

- The maximum pump capacity of the Nyos® OPUS® G2 return pump must not exceed 2,000 l/h (530 gph). If this is exceeded, the display tank could overflow!



INFORMATION ON AUTO TOP OFF SYSTEM

We recommend a separate auto top off system

- Water that evaporates in all areas of the system can only be detected through a drop in the water level in the return chamber. The sensor of the Auto Top Off system needs to be installed in the return chamber.
- Because sea salt does not evaporate, only use fresh water (RODI Water) as compensation for water lost through evaporation.
- **IMPORTANT:** As the refill tank is higher than the water level in the sump, please ensure that the refill water is not being topped up even when the pump is turned off. This can be realized by a de-aeration of the refill tube. Please read instruction of respective manufacturer carefully.



STARTING THE TANK

VIDEO INSTRUCTIONS FOR
STARTING THE TANK



STEP 1: REEF CONSTRUCTION AND SAND:

- We recommend to arrange the aqua scape whilst dry, before filling the aquarium with seawater. This is significantly easier than arranging the reef construction underwater.
- When the aqua scape is finished, the sand can be added.

STEP 2: FILLING WITH SEAWATER

- Before filling for the first time, make sure all technical components (skimmer, return pump, etc.) are installed in compliance with the manufacturer's safety instructions.
- Check the correct installation of the pipework once more. First fully close the valve by turning it clockwise. Fill the overflow box with a little water to test the leak-tightness of the threaded connections on the overflow box.
- Fully open the valve before filling the display tank by turning it counterclockwise.
- Now start to fill the display tank with seawater.
- Once the display tank is almost full, the water starts to flow into the sump via the overflow box. Monitor the water level in the sump. Once the water level in the return chamber is approx. 15cm (6 in), turn on the return pump.

STARTING THE TANK

STEP 3: ADJUSTING THE VALVE

- It is now necessary to adjust the valve of the main outflow: The valve closes through rotation in a clockwise direction. This results in the water level in the overflow box and display tank rising. In order to reduce the water level again, the valve must be correspondingly turned counterclockwise so that the valve opens further.
- As soon as you begin to approach to the correct settings, the valve should only be turned slightly. It takes several minutes for the water level to adjust to the respective valve settings.
- The valve is correctly set if no further outflow noise can be heard and the desired water level in the display tank has been reached. We recommend a water level of approx. 2,5-3 cm (0.9 – 1 in) below the top edge of the display tank. With this, no water (or very little water) should flow via the emergency outflow.
- Now turn on the skimmer. Note that the skimmer can overflow for a short while depending on the configuration (e.g. with fresh live rocks). Turn the skimmer down as far as possible and remove the cup if necessary. This effect will subside after a couple of days.

STARTING THE TANK

STEP 4: SIMULATION OF POWER FAILURE

- Disconnect all electrical equipment from the mains and test to ensure the sump does not overflow in the event of a power failure. There is no risk of this if the valve is correctly set.

MAINTENANCE AND CARE

FILTER SOCK:

- The filter sock must be cleaned at regular intervals. Rinse out the filter sock under running water or wash it in the washing machine on a cold setting. We generally recommend keeping a number of filter socks in stock.
- Note: If the filter sock is clogged, the water no longer flows through the filter sock but rather over it. The function of the sump remains intact.

MAINTENANCE AND CARE

REFILL TANK:

- The refill tank contains water for a number of days (depending on the ambient temperature, water temperature, etc.). Make sure there is always sufficient refill water (RODI) available, otherwise the return pump can run dry and the water exchange between the sump and display tank will be interrupted.

OVERFLOW BOX:

- Clean the pump outlet and the filter comb on the overflow box at regular intervals to remove algae, deposits, etc.
- Check that no foreign bodies are present inside the outflow and emergency outflow.
- Clean the pipes of encrustations, coralline algae, etc. at regular intervals.

CABINET:

- Only clean the cabinet with water and a soft cloth. Do not use any aggressive cleaning products.
- Make sure no water runs beneath the cabinet. Wipe up water on the floor immediately.
- Make sure no water runs down the panes of the display tank.
- Only OPUS® G2 Pro-Line®: If water lands on the silicone cord, wipe this off immediately.

MAINTENANCE AND CARE

- Make sure no water is present inside the cabinet, around the sump.

DISPLAY TANK:

- When cleaning the panes of the display tank and sump with a scraper, make sure the blades do not damage the silicone seams.
- Do not use magnetic cleaners to clean the rear pane of the display tank because the paint on the outside of the rear pane may be damaged.



www.facebook.com/nyos.aquatics



Nyos® Aquatics GmbH
Siemensstr. 26
70825 Korntal-Muenchingen, Germany
www.nyos.info, support@nyos.info